

# MOHANA Renewcare



## 1 MW / 2.612 MWh BESS Product Specifications

**1 Product requirements instructions..... 1**

**1.1 Abbreviations ..... 1**

**1.2 Reference standard ..... 1**

**1.3 Scope ..... 2**

**2 General product description ..... 3**

**2.1 Product parameters ..... 3**

**2.2 Introduction to system equipment ..... 4**

**2.3 Primary electrical schematics..... 6**

**2.4 Product layout..... 7**

**2.5 Product features ..... 8**

**3 Product introduction..... 10**

**3.2 Battery cluster control box (CCB) ..... 12**

**3.3. Power conversion system (PCS) ..... 13**

**3.4 Temperature control system ..... 15**

**3.5 Fire suppression system..... 19**

**3.6 BMS introduction ..... 22**

**3.7 Electrical cabinet ..... 24**

**4 Product maintenance..... 26**

Revision Record

Version	Revise History	Reviser	Date
V0	Initial issue	Kumar	2025-01-01

## 1 Product requirements instructions

### 1.1 Abbreviations

BMU	Battery management system (slave control)
BCMS	Battery management system (main control)
EMS	Energy management system
PCS	Power on version system
BESS	Battery storage system
MCCB	Molded Case Circuit Breaker.

### 1.2 Reference standard

- IEC 62485-1:2018-Safety requirements for secondary batteries and battery installations.
- IEC 62619:2017-Secondary cells and batteries containing alkaline or other non-acid electrolytes - Safety requirements for secondary lithium cells and batteries, for use in industrial applications.
- IEC 60695-1-11 - Fire hazard assessment.
- NFPA 855 - Standard for the Installation of Stationary Energy Storage Systems.
- IEC 62933-1 Electrical energy storage (EES) systems - Part 1: General requirements.
- IEC 62933-2-1 Electrical energy storage (EES) systems - Part 2-1: Unit parameters and testing methods - General specification.
- IEC 62933-3-1 Electrical energy storage (EES) systems - Part 3-1: Planning and performance assessment of electrical energy storage systems - General specification.
- IEC 62933-4-1 Electrical energy storage (EES) systems - Part 4-1: Guidance on environmental issues - General specification.
- IEC 62933-5-2 Electrical energy storage (EES) systems - Part 5-2: Safety requirements for grid integrated EES systems - Electrochemical based system.
- IEC 62477-1 Safety requirements for power electronic converter systems– Part 1: General requirements.
- IEC 61000-2 Electromagnetic compatibility (EMC) – Part 2: Environment.
- IEC 61000-4 Electromagnetic compatibility (EMC) – Part 4: Testing and measurement techniques.
- IEC 63056 Functional safety of electrical, electronic, and programmable electronic systems.
- NFPA 69 Standards on Explosion Prevention Systems.
- IEC 60445 Basic and safety principles for man-machine interface, marking and identification.
- IEC 61439 Low-voltage switchgear and control gear assemblies.

- IEC 61643-11 Surge protective devices – Part 11: Surge protective devices connected to low-voltage power distribution systems – Performance requirements and testing methods.

### 1.3 Scope

This document outlines the safety guidelines, features, requirements, service and maintenance procedures, and warranty information for the All-in-one Liquid Cooled Container. Its primary purpose is to ensure the safe handling and operation of the product. If any details regarding usage or specifications are unclear, please contact Mohana renew care private Ltd. for further assistance.

## 2 General Product Description

### 2.1 Product Parameters

Industrial and commercial storage 2.612 MWh system			
Product type	Lithium iron phosphate battery system		
NO.	Items	Specifications	
1	Configuration	10* (1P52S*5)	
2	Rated power	2.612 MWh	
DC side			
3	Rated voltage	832V DC	
4	Voltage range	702-936V DC	
AC side			
5	Rated voltage	400V AC	
6	Grid frequency	50/60Hz	
7	Rated current	1520A	
8	Rated charging	1.05 MW	
9	Rated discharge	1.05 MW	
Container parameters			
10	Interface configuration	3P+N+PE (N is reserved)	
11	Environmental conditions	Storage temperature	-35°C ~+50°C
		Operating temperature	-30°C~+50°C(Derated use above 45°C)
		Application Altitude	≤5000m( Derated above 2000m)

12	Basic parameters	Color	RAL 9003
		Weight	≈27t
		IP grade	IP55
		Anticorrosion rating	C4(C5: optional)
		Cooling method	Liquid cooling
		Communication protocol	PCS: CAN/RS485/Ethernet EMS: Ethernet
		Coolant	50% Glycol solution

### 1.1 Introduction to System Equipment

The 2.612 MWh All-in-One Liquid Cooled Energy Storage Container is a high-energy-density energy storage solution. It integrates various essential systems, including battery cluster units, battery management system (BMS), power conversion system (PCS), fire protection system, lighting system, thermal management system, ventilation system, and electrical system, among others.

Table 2.2-1 2.612 MWh parameter

NO.	Device	Technical requirements	Quantity	Unit	Remarks
1	Battery container	20HC Liquid Cooled Energy Storage Container with 2.612 MWh capacity	1	set	1.1~1.4
1.1	Liquid cooled unit cabin	Liquid cooling unit with cooling capacity of 45 KW	1	set	
1.2	Electrical cabinet	The interior of the system Includes the bus system, communication and control system, power distribution system as well as auxiliary system like fire suppression system and air conditioner.	1	set	
1.2.1	Busbar	AC bus, 10 MCCBs	10	set	
1.2.2	Power Distribution	Including auxiliary power distribution of the entire battery compartment, power distribution of the liquid cooling unit, UPS	1	set	

	System	power supply, etc.			
1.2.3	Communication and control system	EMS, switches, etc.	1	set	
1.2.4	Fire Suppression System	Including gas extinguishing medium, fire control panel,	1	set	
1.2.5	Air conditioner	Heat dissipation of the electrical cabinet requires a refrigeration air conditioner with a cooling capacity of 2 KW	1	set	
1.2.6	Internal Cables	Internal cables, accessories, etc.	1	set	
1.2.7	Lighting	Electrical cabinet lighting	1	set	
1.3	Battery	Battery cluster, charge and	1	set	
1.3.1	Battery cluster	Contains 5*1P52S module (contains BMU), cluster control box (contains BC), PCS	10	set	
1.3.2	Fire Suppression System	Including smoke detectors, heat detectors, combustible gas detectors, sound and light alarm system, and reserved dry water pipe	1	set	
1.3.3	Ventilation system	Inlet louvers, exhaust fans, air ducts	1	set	
1.3.4	Internal Cable	Internal cables, accessories, etc.	1	set	
1.4	Enclosure	6058*2438*2896mm containers, internal cables, etc.	1	set	

### 1.1 Primary Electrical Schematics

The BESS has a total capacity of 2.612 MWh and integrates the battery system, BMS, PCS, fire suppression system, liquid cooling unit, environmental monitoring, etc... The primary electrical schematic diagram is shown below.

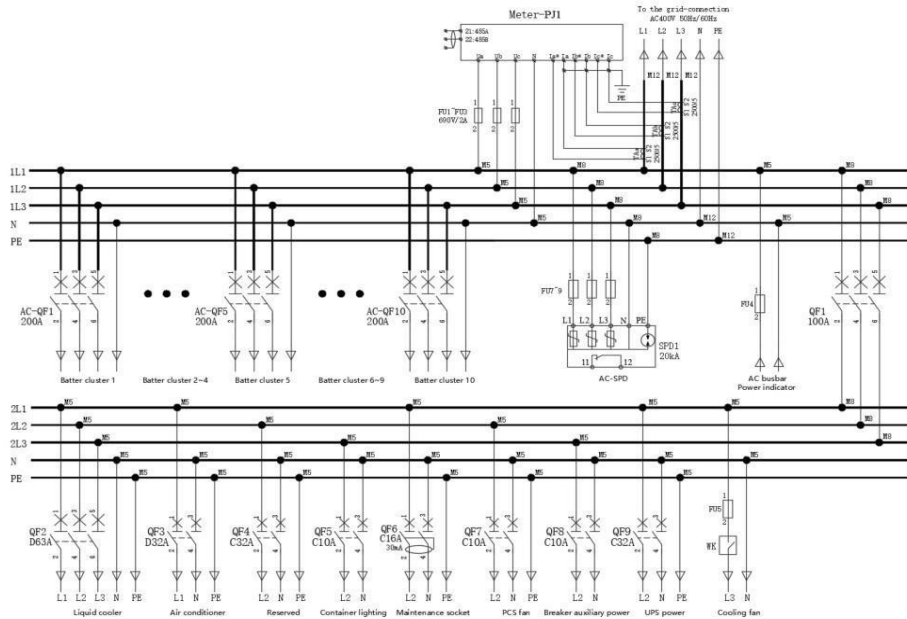

Figure 2.3-1 Primary Electrical Schematic

### 1.1 Product Layout

Internal layout of a single container

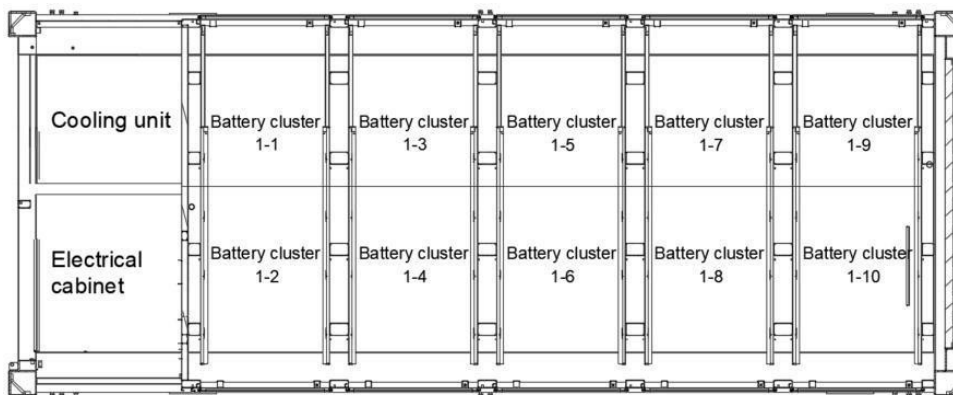

Figure 2.4.1-1 Internal layout of a Single Container

## 2.4.2 Installation Layout Drawing

The spacing of long side with battery doors between the containers is not less than 3.5m, and the end side with the chiller spacing with the fence is not less than 4m. The end side without chiller can be placed together with only 200mm distance

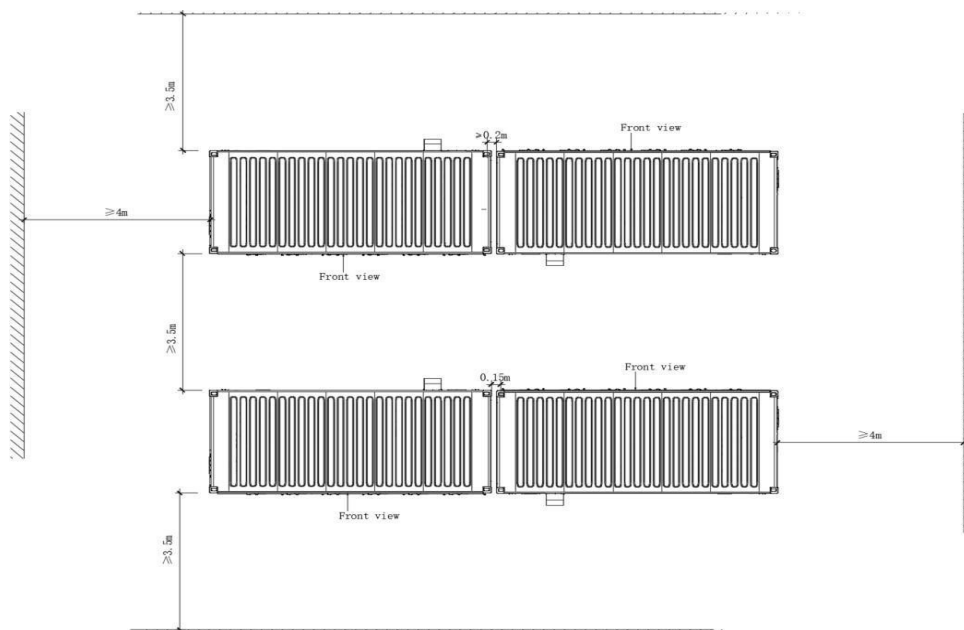

Figure 2.4.2-1 Installation layout drawing

## 2.2 Product Features

### Safe

- 1h fire resistance.
- 3-level BMS architecture.
- Holistic Cell Data Management.
- 6-level electrical protection.
- String PCS leads to a smaller short-circuits current in the event of faults.
- Comprehensive fire protection system.
- CE marked.

### Economical and Efficient

- Intelligent liquid cooled temperature control.

- Extremely uniform temperature (temperature difference among cells lower than 5 °C) field to keep the system longer cycle life.
- Low auxiliary consumption.
- OSS system to make the O&M easier and more visible.
- Plug and Play.

**Versatile**

- Compatible with different European market grid connection standards.
- Less space occupancy.
- Flexible and configurable.

**Smart**

- Cloud plus Mobile App.
- Active balancing.
- OTA upgrade.

**3 Product Introduction**

**3.1 Battery module**

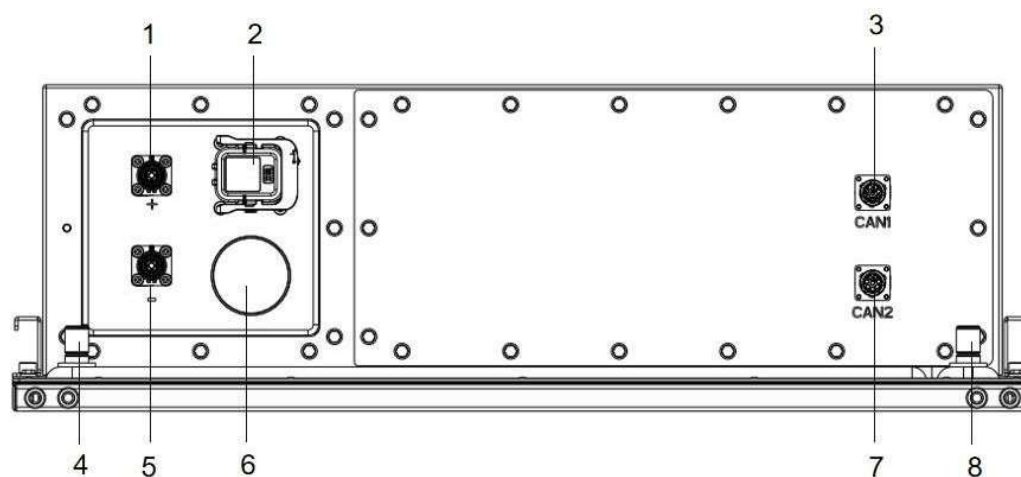

Figure 3.1-1 Battery Module

**Table 3.1-1 Battery Module**

NO.	Description	Instructions
1	Positive terminal	IP67 quick plug
2	MSD	Manual Service Disconnect
3	CAN Communication 1	IP67 quick plug
4	Coolant inlet	Aluminum alloy
5	Negative terminal	IP67 quick plug
6	Explosion-proof vent valve	Aluminum alloy
7	CAN Communication 2	IP67 quick plug
8	Coolant outlet	Aluminum alloy

The battery module is composed of 52 cells and 4 BMUs. It features 32 NTC temperature sampling points and 56 voltage sampling points for precise monitoring. The BMUs are responsible for measuring individual cell voltages, the total module voltage, and cell temperature. These BMUs actively report real-time monitoring data to the BCMS via the CAN 2.0 communication bus. Additionally, they execute the temperature control and balancing strategies issued by the BCMS to ensure optimal performance and safety.

### 3.1.1 Battery Module Parameters

Table 3.1.1-1 Battery Module parameters

NO.	Description	Specification parameters	Remarks
1	Series parallel mode	1P52S	
2	Nominal capacity	314Ah	
3	Nominal voltage	166.4V	
4	Voltage range	140V~187.2V	
5	Energy capacity	52.2 KWh	
6	Charging current	≤0.5 C	
7	Discharge current	≤0.5 C	
8	Dimensions	1105*800*245mm	

9	Weight	325±5kg	
10	Self-discharge rate	Monthly self-discharge <3%	
11	IP rating	IP67	
12	Optimum operating temperature	15°C~35°C	
13	Storage temperature	-30°C~55°C	
14	Cooling method	Liquid cooling	

### 1.1.1 Module Precautions

All tests were conducted at ambient temperature (25°C) unless otherwise noted.

The battery module is charged at a constant power of 25.1KW to the cut-off voltage of either cell (3.6V) or module (374.4V) and then discharged at a constant power of 25.1KW to the cut-off voltage of either cell (2.75V) or module (286V). After each charge and discharge, the battery module should be left to stand for at least 30 minutes.

## 1.2 Battery Cluster Control Box (CCB)

### 1.2.1 CCB Parameters

Table 3.2.1-1 CCB parameters

NO.	Item	Parameters
1	Rated voltage	1500V DC
2	Rated current	250A
3	Breaking capacity	150KA
4	IP rating	IP54
5	Altitude	≤2000m
6	Operating temperature	-30~50°C
7	Humidity	0~95% RH
8	Dimensions	W*D*H 800*830*222mm

### 1.1.1 CCB Primary Diagram

The CCB is suitable for 20-foot 2.612 MWh battery cabinet. The overall design is based on the product meeting the CE standard.

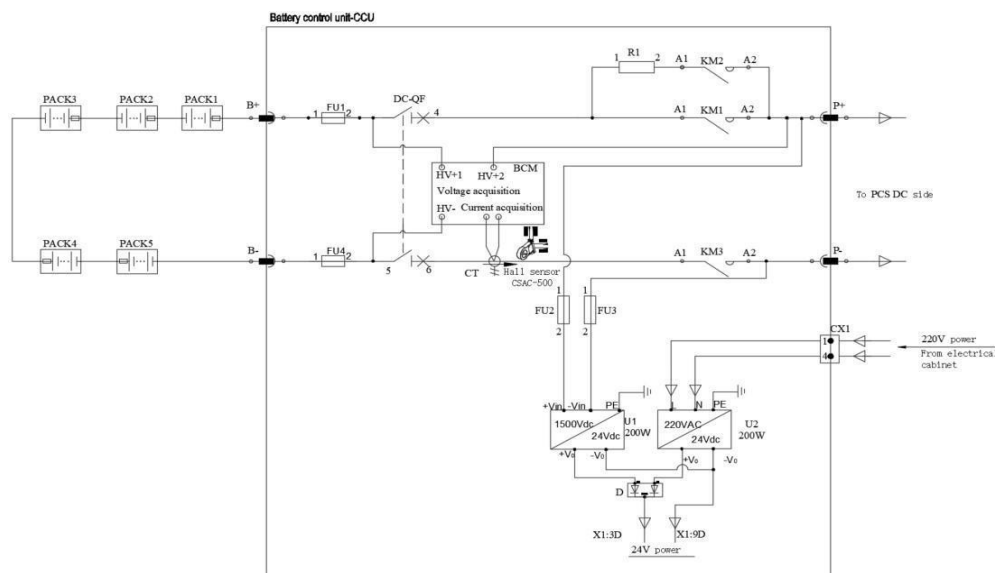

Figure 3.2.2-1 CCB primary diagram

## 3.3. Power Conversion System (PCS)

### 3.3.1 PCS Instructions

The PCS can control the charging and discharging process of the battery. PCS consists of bi-directional AC/DC converter, control unit, etc. The bi-directional AC/DC converter is the power part that realizes the bi-directional conversion of AC and DC, and the control unit is the control part, which receives the control commands through the communication interface, and then sends the commands to the power part to realize the charging/discharging control of the battery, and then realizes the regulation of the active power and reactive power of the power grid. The PCS can also be operated off-grid to provide energy to the load in an island environment.

The PCS control unit of the energy storage converter communicates with the BMS through the CAN interface to obtain the status information of the battery pack, realize the protective charging and discharging of the battery, and ensure the safe operation of the battery. At the same time, PCS communicates with energy management system EMS through RS485 interface to achieve peak

cutting and valley filling, peak and frequency regulation, virtual capacity addition and off grid backup.



Figure 3.3.1-1 View of PCS

### 3.3.1 Parameters of PCS AC side

Table 3.3.2-1 Parameters of PCS AC side

NO.	Name	Parameters
1	Rated voltage	400V AC
2	Rated output power	105 KW
3	Maximum output power	115.5 KW
4	Rated grid frequency	50/60Hz
5	Power factor	0.99
6	Power factor range	1(lead) ~ 1(lag)
7	Current distortion rate	<3% (rated power)
8	Dimensions	W*D*H484*703*256.5 mm
9	Weight	50kg
10	Communication	CAN/RS485/Ethernet

### 3.4 Temperature Control System

#### 3.4.1 System Overview

The battery module liquid chiller of the container belongs to the air-cooled liquid cooling unit, and the condenser releases the heat into the outside air through the fan. The liquid cooling system is equipped with circulating water pump according to the waterway and the resistance of the battery module to ensure that the liquid flow through each liquid cooled battery module is basically equal and meets the uniform temperature requirements of all batteries in a system.

#### 3.4.2 System Functions

The system adopts "double cycle" structure for heat dissipation, double energy efficiency control, multi-level distribution of liquid cooling pipes, and temperature difference control of any PACK is controlled within 2°C.

The unit has the monitoring function of the upper computer, and the communication between the chiller and the host is realized through RS485, control mode optional automatic mode or cell temperature control mode, each branch set flow meter and regulating valve, flow independent monitoring and control.

Dual power system, backup power supply, leakage protection, solid state relay, emergency stop button multiple protection, real-time feedback coolant leakage signal to prevent leakage safety accidents. Data real-time reporting system, the real-time running state, the fault for the first time feedback.

#### 3.4.3 Effect of Temperature Control

##### 1) Container internal environment temperature control

The ambient temperature inside the container is controlled at  $25\pm 5^{\circ}\text{C}$ . 2) Battery temperature control.

The temperature of the single cell is controlled at  $20\sim 40^{\circ}\text{C}$ .

##### 2) Temperature difference control.

The temperature difference of all batteries in the energy storage container is controlled within 2°C.

##### 3) Temperature control target under extreme conditions.

Under the external environmental conditions of  $20\sim 45^{\circ}\text{C}$ , ensure that the temperature in the container, the battery temperature, and the temperature difference in the system is controlled in the above range to ensure the smooth operation of the energy storage system. The operating

state of the unit is adjusted in real time according to the temperature of the battery cell, and the standby, cooling and heating modes are switched in real time according to the temperature of the battery cell to achieve the highest energy efficiency ratio.

### 3.4.4 General Introduction

**1. This product is cooled by liquid cooling.**

The temperature control system includes liquid cooling unit, pipeline, coolant and other components of the pipeline according to the location are divided into one, two, three levels.

The first level pipeline is the main pipeline, which is connected to the total inlet and outlet of the liquid cooling unit.

The secondary pipeline is the main pipeline in the cluster, which matches the number of clusters.

Level 3 for docking module pipe, liquid-cooled access module board in and out of the gate.

**2. Note: The coolant of the Temperature control system has the following precautions.**

About the service life: the service life of the coolant is 5 years, and it is maintenance-free during the service cycle of the coolant period. After 5 years, samples can be sent back to our company for testing, and our company will give opinions on the use according to the test results.

On the disposal of the waste liquid: please send the waste liquid to the official designated waste oil(liquid)treatment center, do not dump in the soil, drainage pipes and water, so as not to harm the natural environment and human health, under normal circumstances harmless use.

**3. Principle of Temperature control system**

The chiller consists of a refrigeration circulation system and a cooling liquid circulation system. The system is shown in the figure.

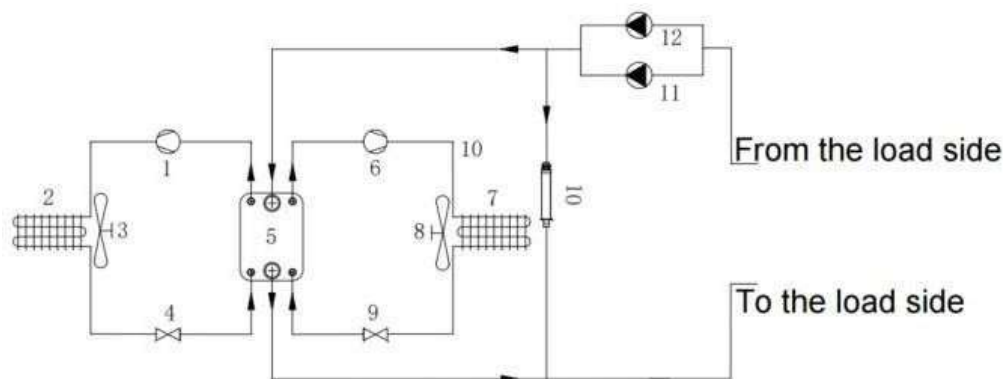

Figure 3.3.4-1 Chiller schematic diagram

Table 3.4.4-1 Chiller instruction

NO.	Name
1	1# compressor
2	1# condenser
3	1# condenser fan
4	1# throttling element
5	Plate heat exchanger
6	2# compressor
7	2# condenser
8	2# condenser fan
9	2# throttling element
10	Electric heater
11	1# circulating pump
12	2# circulating pump

- Compressor: It is responsible for compressing the refrigerant and providing power for the refrigeration system.
- Condenser: The finned tube heat exchanger is designed with high heat exchange efficiency, and the refrigerant condenses in the condenser to release heat.
- Condenser fan: centrifugal fan is used to discharge the heat released by the refrigerant in the condenser to the outside.
- Throttling element: Electronic expansion valve is used to control the refrigerant flow by adjusting the opening.
- Plate heat exchanger: plate heat exchanger is the junction of refrigeration circulation system and coolant circulation system, is responsible for the heat exchange between refrigerant and coolant.
- Electric heater: it is responsible for heating the coolant.
- Circulating pump: it is responsible for conveying coolant and providing power for the coolant circulation system.

## 4 Work Flow

The working process of chiller is as follows:

a. When the outlet coolant temperature reaches

At the refrigeration opening point, the compressor starts to compress the gaseous refrigerant. The control system of the air-cooled water chiller regulates the speed of the compressor motor related to the load according to the outlet temperature or the demand issued by the upper computer, so as to control the power of the Whole machine and the outlet temperature.

b. The condenser condenses the high-temperature gaseous refrigerant. The gaseous refrigerant is condensed into liquid by cooling, and the heat is discharged to the ambient air by the fan through the surface of the condenser.

c. The condensed refrigerant is throttled and depressurized by the electronic expansion valve and then injected into the plate heat exchanger. The refrigerant evaporates in the plate heat exchanger and absorbs the heat of the coolant.

d. The circulating water pump delivers the coolant to the plate heat exchanger for heat exchange with the refrigerant, and delivers the cooled coolant to the container for cooling the battery pack.

### 4.4 Fire Suppression System

#### 4.4.1 Design Main Design Principles

1. Fire suppression system consists of cabinet type aerosol fire extinguishing device, pipeline and nozzle, etc.
2. All equipment of automatic fire alarm system adopts bus system. The area is composed of automatic gas extinguishing panel, smoke detector, temperature detector, fire sound and light alarm, and the emergency start and stop button, gas discharge indicator light, fire sound alarm and hand automatic conversion box are set outside the area.
3. The combustible gas alarm system is composed of a combustible gas controller and a combustible gas detector. Combustible gas alarm system can control the ventilation system (exhaust air volume to meet the requirements of 1-minute container air exchange, exhaust fans and electric louvers should be closed before gas fire extinguishing)

#### 4.4.2 Control linkage

##### **( I ) Combustible Gas System Logic:**

When the concentration of any combustible gas detector reaches the first threshold, after the automatic gas extinguishing panel receives the signal, the system enters the pre-fire alarm state, starts the sound and light alarm and starts the ventilation system at the same time, sends the signal to BMS, and cut off the auxiliary power supply such as PCS and air conditioning.

When the system enters the main fire alarm state, close the ventilation system and enter the spray delay stage.

##### **( II ) Fire Alarm System Fire Extinguishing Logic:**

###### **(1) When the system is in the automatic start state:**

a. When the automatic gas extinguishing panel receives a single alarm signal from any temperature detector, smoke detector and manual alarm button in the battery compartment, the system enters the pre-fire state and the same time sends this signal (pre-fire alarm) to the BMS and starts the sound and light alarm to send the sound and light alarm.

b. When the automatic gas extinguishing panel receives the following combination of signals: Any combination of the first threshold signal of a combustible gas detector and any temperature detector signal, or any two combinations of the three signals of the temperature detector, smoke detector and manual alarm button, or the combination of the second threshold signal of two combustible gas detectors at the same time, the system enters the main fire alarm state and has the following actions:

- Activate the external sound & light alarm to alert the duty personnel of the fire situation.

- After receiving the signal, the automatic gas extinguishing panel will send the information to the BMS system, which will cut off the PCS power supply, BMS and auxiliary electric air conditioning and other power supplies, and close the exhaust ventilation system at the same time.

- The automatic gas extinguishing panel sends the fire extinguishing command, and opens the bottle valve of the battery bin fire suppression device to spray all the aerosol after a delay of 30s.

- After receiving the fire extinguishing feedback signal, the automatic gas extinguishing panel starts the gas discharge indicator light to ensure that the open flame can be extinguished quickly after spraying.

###### **(2) Emergency Manual Start State:**

a. When personnel enter the battery compartment for maintenance, switch to the manual start state, and devices in the system will not start together at this time.

b. When the personnel find the fire, press the emergency start button to start manually. After the automatic gas extinguishing panel receives the start signal, the system enters the main fire alarm state, and the operation process is the same as the automatic start state.

### 4.4.3 Logic Diagram

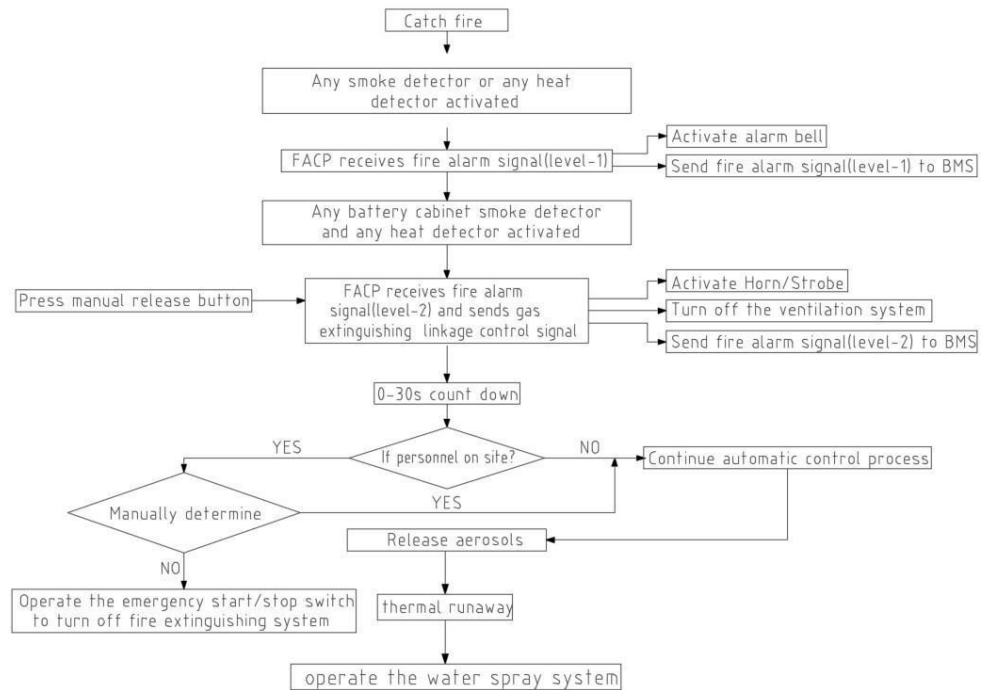

Logic diagram of the fire alarm system and aerosol fire extinguishing system

Figure 3.5.3-1 Logic diagram of the fire alarm system and aerosol fire extinguishing system

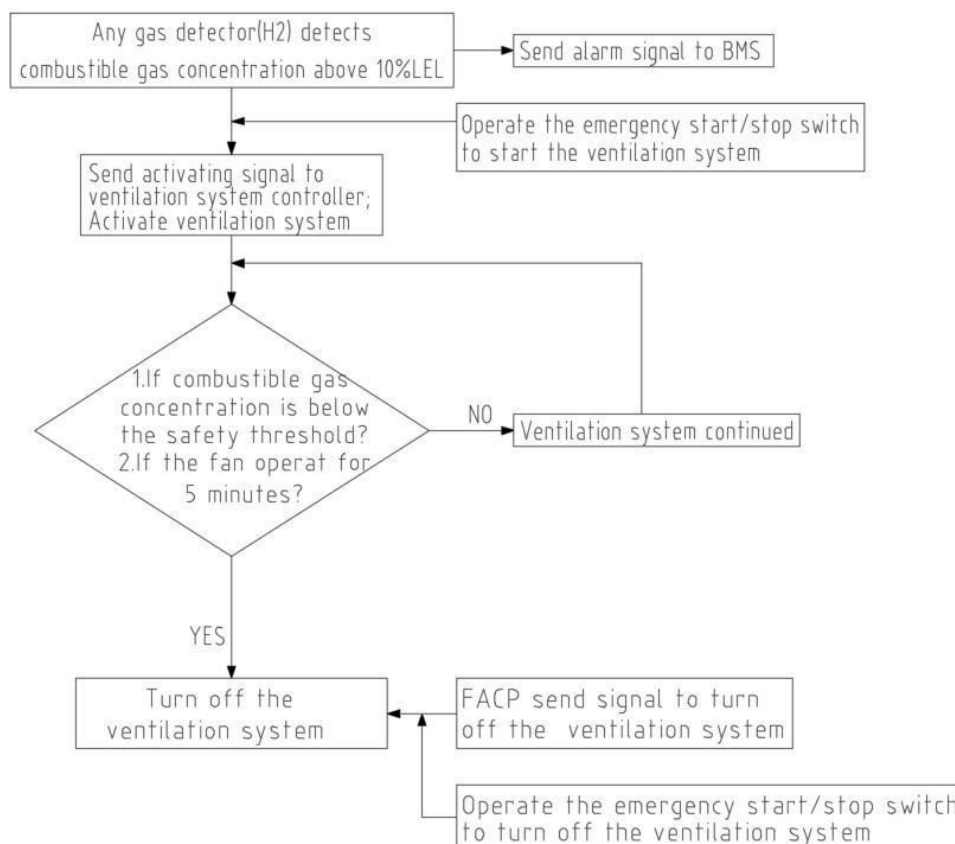

## Logic diagram of the ventilation system

Figure 3.5.3-2 Logic diagram of the ventilation system

### 3.6 BMS Introduction

The main components of the energy storage battery management system include: BCMS, BMU, secondary battery management architecture, and full data upload EMS.

The BCMS mainly obtains the voltage, current, and temperature information of battery clusters and battery modules for processing calculates the SOC, SOH, charge and discharge capacity of battery stacks, and system operating alarms and protection status. Based on the obtained data and calculation results, the BCMS implements corresponding scheduling policies, temperature control policies, and balancing plans. Record the important operation, alarm and protection log files, record all the operating information of the battery stack in real time during the operation of the system, and can accept EMS scheduling, send data to the cloud platform, ESS management platform, etc.

The battery management BMU collects the voltage, temperature, balanced voltage, balanced current, total battery string voltage, pressure data, fan speed, etc., calculates the characteristic information, alarm and protection status of the battery, records the important logs and events during the operation of the battery module, and executes the temperature control policy and balance policy issued by the BCMS. At the same time, the BMU reports battery data to the BCMS.

The environmental monitoring management unit is integrated in the EMS, Which mainly collects the operating status of the environment, power, security, fire and other equipment, obtains the temperature and humidity data in the container, calculates the heat distribution data in the container, regulates the temperature in the container according to the data of batteries and other equipment in the container, controls the fan and air conditioner, and records the important logs, events, temperature and other data during the system operation. At the same time upload the data to DTU, cloud platform and so on.

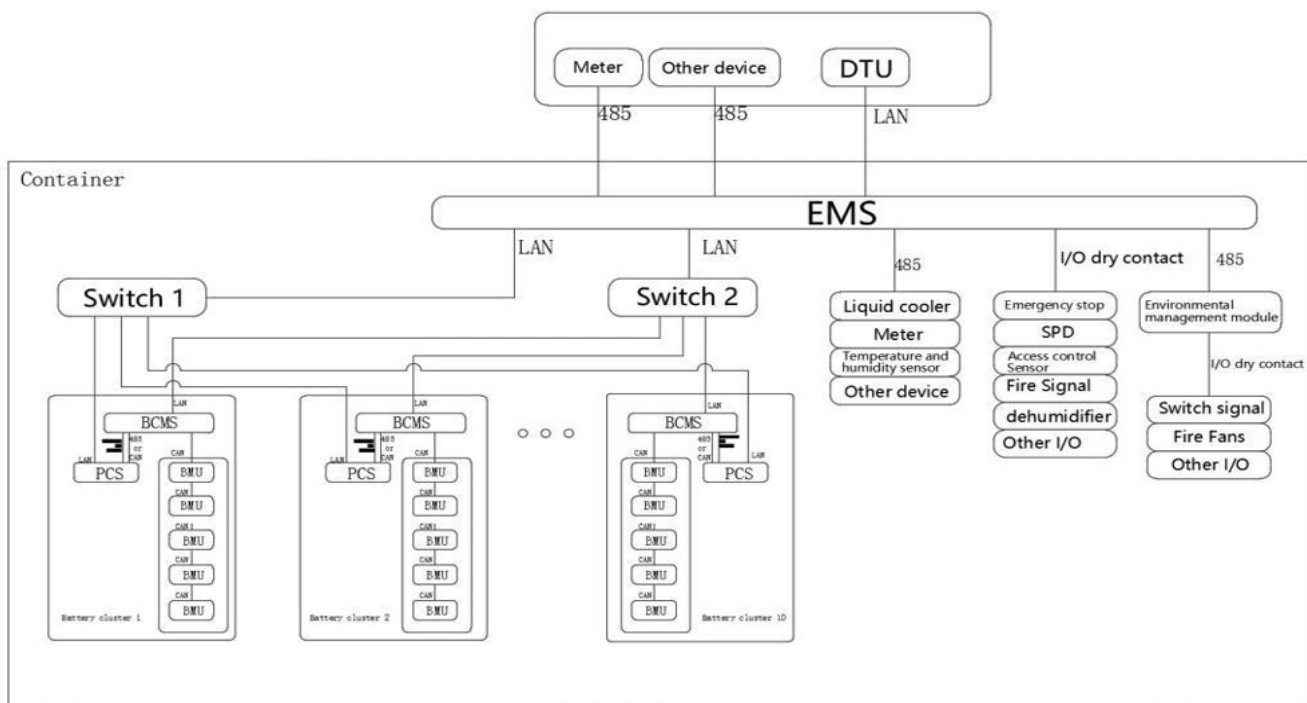

Figure 3.6-1 Communications topology

### 3.7 Electrical Cabinet

The electrical cabinet is one of the sub-compartments of the 2.612 MWh energy storage containers, and the whole is separated from the battery compartment to avoid the spread of fire. The interior of

the electrical cabinet includes the communication part, the auxiliary distribution part, the bus part, etc.

#### 1) **Battery management and confluence**

The bus MCCB and EMS are installed. The PCS output of each battery cluster is connected to the inlet line side of the bus switch, and the outlet line of the bus switch is connected to the copper bar of the bus bar, so as to realize the function of the bus cluster and control.

At the same time, the EMS detects the voltage, current, insulation and other information of the main AC loop, receives the information of the BMS (battery management master) downward, and receives the commands of the Data transfer unit (DTU) or monitoring background upward. Combined with its own protection logic, the battery stack can be managed and protected.

#### 2) **Container power distribution**

The battery compartment meets all the power distribution functions in the battery container, including: the electricity meter collects the self-consumption situation in the container, and the incoming line design surge protector, try to make the three phase load balance in the container, each branch has a complete protection function, and complete the AC power supply of industrial air conditioning, lighting, fire suppression, emergency lights, and sockets inside and outside the cabinet in the container.

Important load configuration backup power supply, after the mains failure, to achieve uninterrupted power supply  $\geq 30$  minutes.

#### 3) **Environmental management function**

The environment management unit is designed in the system cabinet, which can collect the temperature and humidity status in the container, the MCCB status of each component, the operation status of air conditioning, water prohibition, fire protection status, surge protector status, mains fault status and other information. And upload all kinds of information to the monitoring background.

#### 4) **Emergency stop function**

The emergency stop button is installed inside and outside the container. Pressing the emergency button can realize the stop of the whole container; realize the DC circuit opening, and the auxiliary power supply incoming line switch opening. And upload the emergency stop status to BMS and monitoring background. When the container fire occurs, the fire suppression system sends out the fire alarm signal, realizes the DC circuit opening, and the auxiliary power supply incoming line switch opening. And upload the emergency stop state to EMS. The container supports remote hard-wired emergency shutdown, can operate the energy storage system emergency shutdown in the monitoring room, to realize the DC circuit switch, auxiliary power

supply line switch. And upload the emergency stop status to EMS. When emergency shutdown occurs in BMS, the DC circuit can be opened and the auxiliary power supply MCCB can be opened. And upload the emergency stop status to PCS and monitoring background.

#### 4 Product Maintenance

1. In order to ensure the safety of maintenance or over haul personnel, before maintenance or overhaul, it is necessary to ensure that the system is shut down, the power supply of all parts has been disconnected, and the necessary short circuit and grounding are carried out, and the necessary maintenance signs are placed to avoid other personnel to power on the system during maintenance

2. In order to ensure the continuous normal operation of the energy storage equipment and the service life of the equipment, it is necessary to frequently maintain the equipment.

(1) The installation and storage of the internal components of the container should avoid highly corrosive and dusty environments, and stay away from flammable and explosive gases.

(2) Regularly check whether the wiring and terminals are aging, and whether the connection points are tight and safe.

(3) Clean the fan regularly and check whether the fan can operate normally.

(4) Before maintenance, the power supply should be completely cut off before operation.

(5) When disassembling the operation, attention should be paid to the operation after the battery discharge is completed.

Note: Refer to the Operations and Maintenance manual for more details.

---

#### Contact us:

Address: **Mohana Renew Care Private Limited**  
147, SIDCO Industrial Estate, Malumichampatti (PO),  
Coimbatore – 641 050

E-Mail: [marketing@mohanarenewcare.com](mailto:marketing@mohanarenewcare.com)

Call us: +919043993857